

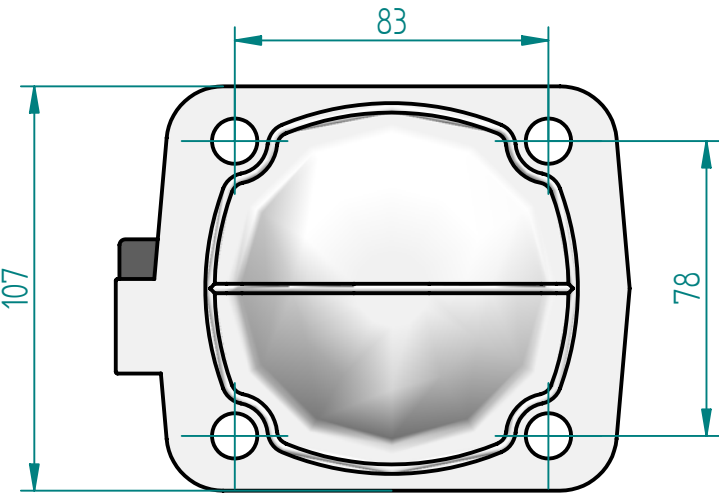

REVISION HISTORY

REV	DESCRIPTION	DATE	APPROVED

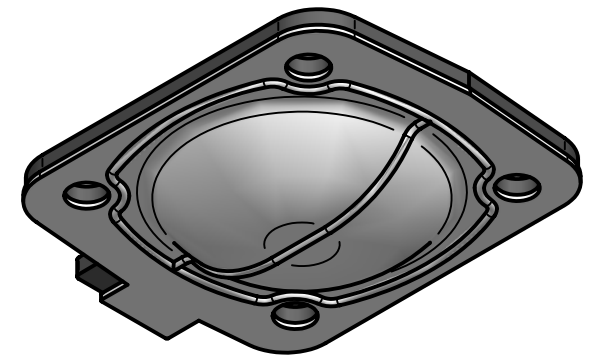
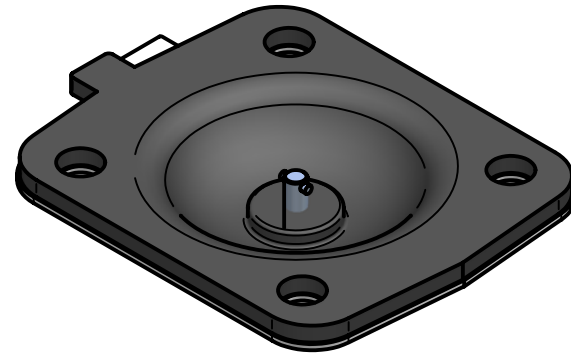
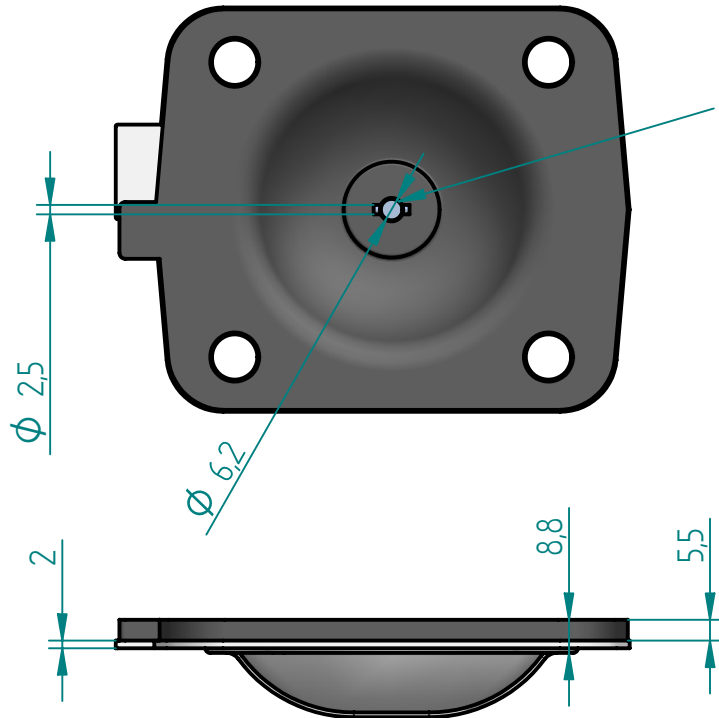

Replacement Diaphragm for :-
 OEM PART = DA050S5
 USED ON 2" (DN50) Diaphragm Valve

	NAME	DATE	 DIAPHRAGM DIRECT
DRAWN	M. MC KEON	02/25/15	
CHECKED			
Material - EPDM BACKING TFM - DIAPHRAGM			TITLE DD20-STFM-C
Complies with CFR 177.2600 and Conforms to USP Class VI Biological Reactivity Tests Section #87 and #88			SIZE A FOOT PRINT DIMENSIONS REV A
FILE NAME: DD20-STFM-C.dft			SCALE: 1 : 125 ECO:0605 SHEET 1 OF 1

Disclaimer - Diaphragm Direct® does not manufacture, represent, nor sell OEM valves or diaphragms manufactured by any other company. Diaphragm Direct® brand diaphragms are not sponsored by any other manufacturers. Any name, model, part number, brand, image, material or referral is for descriptive purposes only. Diaphragm Direct® brand replacement diaphragms are guaranteed to fit OEM equipment and meet or exceed OEM specifications. Diaphragm Direct® brand replacement diaphragms are covered by the standard Diaphragm Direct® limited product warranty.